

Terry Lifts

terrylifts.co.uk • 01565 752 800

◇  
**HARMONY FE**  
*Homelift*  
◇

◇ ◇ ◇  
HIGHEST  
QUALITY  
& SAFETY  
STANDARDS  
◇ ◇ ◇



THE SPECIALIST IN MOBILITY LIFTS • TRUSTED FOR OVER 50 YEARS

◆ ◆ ◆  
PROUDLY  
MADE IN  
BRITAIN  
◆ ◆ ◆





# TERRY LIFTS

*the one to trust*

**When it comes to finding a lift, you can be sure the one you're looking for will be the one you find at Terry Lifts.**

Because at Terry Lifts, we take the time to understand exactly what you need. Which means we can provide you with the perfect lift to fit your home and your lifestyle—proudly made in Britain and installed by experts you can trust.

After all, we've been working in the lift industry for more than 50 years, meeting the highest standards in quality and safety. So you can be confident the lift you choose will be there for you for many years to come.

**It's everything you'd expect and nothing less from the one you can trust.**

## Terry Lifts



### *Freedom & choice, all in one lift*

When it comes to finding a home lift, Terry Lifts offers the ideal solution that meets your needs. Whether traveling standing, seated in a wheelchair or together with a carer, the Harmony FE home lift will allow you to move freely between floors safely, smoothly and quietly. The lift features a wide range of cabin sizes to choose from, so you are sure to find a model that fits your needs.

Our Harmony FE Home lift requires much less space than a conventional lift. There is no shaft or structure required and the footprint of the lift is so compact that it can be placed almost anywhere in your home. What's more, you can be sure your lift is made to meet the highest standards, so it will be there for you for many years to come.

[terrylifts.co.uk](http://terrylifts.co.uk) • 01565 752 800



## *For a personalised* **SERVICE**

- Quiet Glide Hydraulic system
- Market Leading range of cabin sizes
- One touch controls
- A quick, no mess, no fuss installation
- Low cabin floor profile

## *For* **SAFETY**

- Telephone in the cabin
- Pressure-sensitive surfaces and safe edges
- In car emergency lowering in case of power cuts and easy-to-use manual lowering
- 30-minute fire and smoke integrity maintained between floors
- Smoke and heat alarms provided on both floors
- Safety glass as standard

## *For* **PEACE OF MIND**

- Designed and manufactured in Britain complying to all relevant safety standards
- A 12-month parts and labour warranty
- Lifetime testing to ensure reliability
- Building control approval on every installation
- Options for extended warranty
- Members of LEIA  
(Lift and Escalator Industry Association)



HIGHEST  
QUALITY  
& SAFETY  
STANDARDS



## *Optional* **EXTRAS**

- Upholstered fold up seat
- Joystick cabin control
- Hand held remote
- Radio isolation fob
- Grab handles
- Mirror
- Cabin side lighting

---

## **CUSTOMISATION**

- Choice of carpet colour
- Alternative cabin colour in a RAL of your choice

**Whatever your requirement, the HFE is available in different sizes, offering flexibility without compromise.**

This information is for guidance only and must not be used for project design. The technical information is available to assist you and our surveyors are on hand to advise. Terry Lifts' policy is one of continuous product development and the company reserves the right to change specifications without notice.

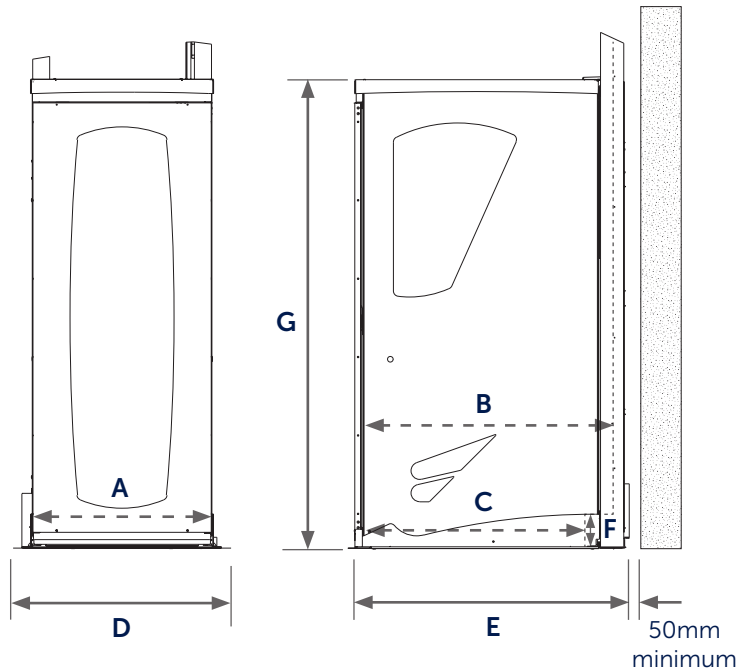

<b>LIFT MODEL</b> *All dimensions in mm	<b>HARMONY FE C</b> (STANDING OR SEATED USE)	<b>HARMONY FE S</b> (STANDARD WHEELCHAIR)	<b>HARMONY FE L</b> (WHEELCHAIR + ATTENDANT)	<b>HARMONY FE LW</b> (WHEELCHAIR + ATTENDANT)
<b>A – Internal width</b>	745	745	745	880
<b>B – Internal length above axle cover</b>	826	1148	1348	1348
<b>C – Internal length to axle cover</b>	726	1045	1245	1245
<b>D – External width</b>	910	910	910	1045
<b>E – External length</b>	914	1235	1435	1435
<b>F – Axle cover height</b>	90	90	90	90
<b>G – Cabin height</b>	2160	2160	2160	2160
<b>Capacity</b>	325kg	325kg	325kg	325kg

THE SPECIALIST IN MOBILITY LIFTS • TRUSTED FOR OVER 50 YEARS

# Terry Lifts

[terrylifts.co.uk](http://terrylifts.co.uk) • 01565 752 800



11/2024 Version: 04